

# FRATELLI INDELICATO S.r.l.

IMPIANTI COMPLETI PER LA TRASFORMAZIONE INDUSTRIALE DI AGRUMI  
COMPLETE PLANTS FOR CITRUS FRUIT PROCESSING

Via Messima 86 - 95014 GARRA (Catania) ITALIA - tel. +39-095-832283 - fax +39-095-837864

LINE FOR THE EXTRACTION OF REAMED JUICE AND  
SFUMATRICE™ ESSENTIAL OIL FROM CITRUS FRUIT

Capacity: 6-8 t/h of fruit

SCALA 1 : 200  
SCALE

Questo disegno e' di nostra proprieta' e non puo' essere riprodotto o usato a terzi senza nostra autorizzazione.  
This drawing is our exclusive property and cannot be copied or given to third parties without our authorization.

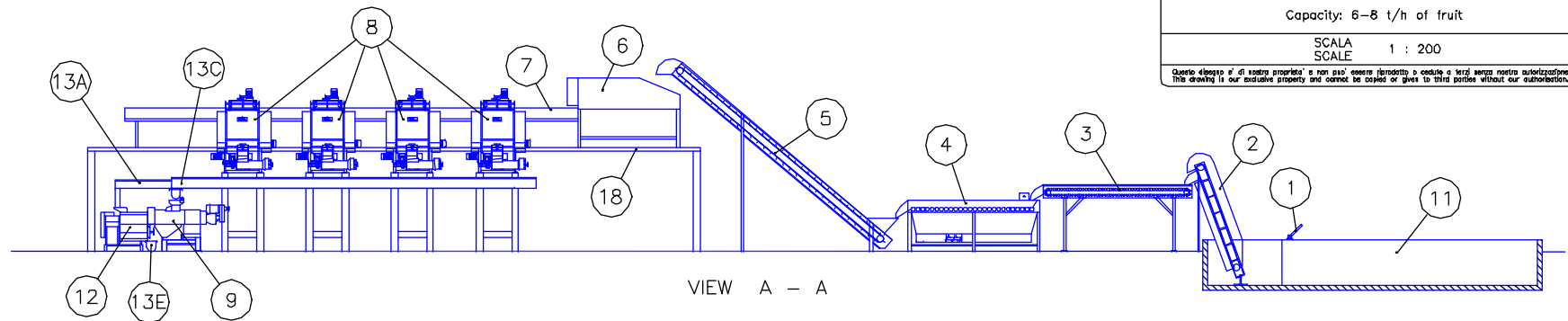

VIEW A - A

## DESCRIPTION

- |  |  |
|--|--|
| 1 - ROTARY FRUIT PUSHER  | 11 - CONCRETE FRUIT RECEPTION TANK         |
| 2 - BELT ELEVATOR 500 x 3200                                   | 12 - EMULSION FINISHER TYPE FV2            |
| 3 - ROLLER INSPECTION TABLE 600 x 4000                         | 13A - SCREW CONVEYOR 150 x 11400           |
| 4 - BRUSHING MACHINE TYPE SK400                                | 13B - SCREW CONVEYOR 150 x 9400            |
| 5 - BELT ELEVATOR 500 x 7700                                   | 13C - SCREW CONVEYOR 250 x 10700           |
| 6 - SIZER TYPE 150/4   | 13D - SCREW CONVEYOR 250 x 2200            |
| 7 - INCLINED BELT 1000 x 14800                                 | 13E - SCREW CONVEYOR 250 x 5000            |
| 8 - 4 EXTRACTION UNITS BIRILLATRICE-<br>SFUMATRICE TYPE AZS204 | 13F - SCREW CONVEYOR 250 x 13000           |
| 9 - POLYPRESS TYPE PL2   | 14A - EMULSION PISTON PUMP                 |
| 10 - HELICAL FINISHER FOR JUICE                                | 14B - 2 EMULSION BUFFER TANKS              |
|  | 14C - DECANTATION TANK WITH 3 COMPARTMENTS |
|  | 14D - PRIMARY JUICE CENTRIFUGAL PUMP       |
|  | 14E - SECONDARY JUICE PISTON PUMP          |
|  | 15 - SWITCH PANEL                          |
|  | 16 - CENTRIFUGAL SEPARATOR (1ST STAGE)     |
|  | 17 - CENTRIFUGAL SEPARATOR (2ND STAGE)     |
|  | 18 - EXTRACTORS SUPPORTING PLATFORM        |
|  | 19 - PEEL SILO                             |
|  | 20 - PEEL SILO SWITCH PANEL                |

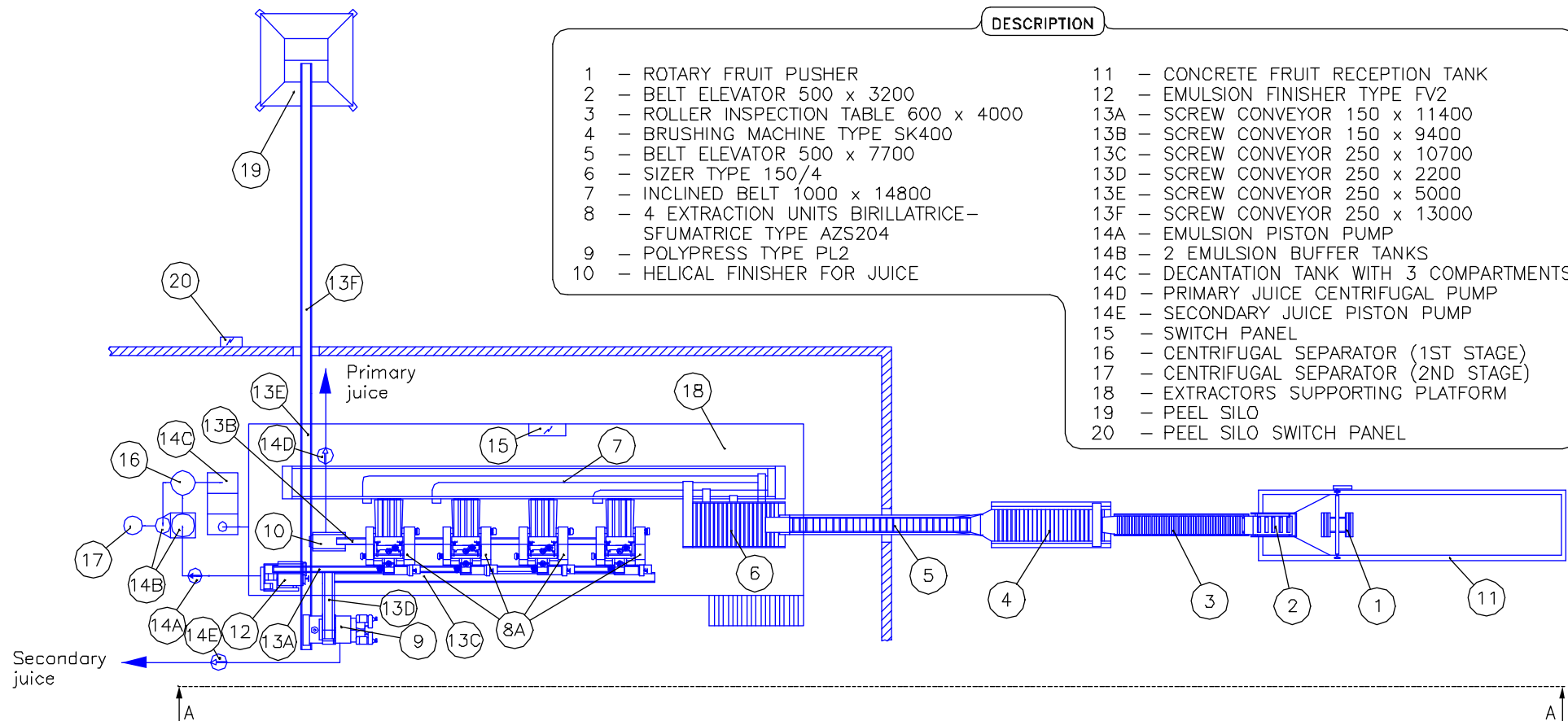

A

A